

Table of Contents

SECTION	PAGE
SECTION 1 INTRODUCTION	1
1.1 Description	1
1.2 Features	1
1.3 Models	2
SECTION 2 RS-232 COMMUNICATIONS	2
2.1 Description	2
2.2 RS-232 Cable Connections	3
2.3 RS-232 PC Screens	3
2.4 Operating Protocol	6
SECTION 3 INSTALLATION	9
3.1 Unpacking	9
3.2 Mounting	9
3.3 Outline Dimensions	10
3.4 Wiring the Power Circuit	10
3.5 Changing Line Voltage Setting	11
3.6 Sensor Placement	12
SECTION 4 PARTS OF THE SCANNER	12
4.1 Front of the Scanner	12
4.2 Button Functions	13
4.3 Back of the Scanner	14
4.4 Temperature/Setpoint Display	15
SECTION 5 SETUP AND OPERATION	15
5.1 "RUN" Mode	15
5.2 Functions	16
5.3 Functions Description	17
5.4 "FUNCTION SELECT" Mode	22
5.5 Security	22
5.6 Entering the Password	23
5.7 Wiring RTD Models	25
5.8 Wiring OC Models	25
5.9 Thermocouple Ranges	26
SECTION 6 SPECIFICATIONS	27

SECTION 1 INTRODUCTION

1.1 Description

The CN600 Series is a second generation of industrial scanners based on the field proven CN100 six zone temperature monitor/alarm system. Several models and options are available.

The CN600 Series is a microprocessor based scanner which accepts signals from thermocouples or RTD's. In the basic unit, six zones are sequentially scanned with a selectable display rate of 1 to 40 seconds each. A single output relay is provided to indicate an alarm condition on any zone. The faceplate has been arranged to call attention to an alarm condition by flashing the main temperature display and indicating the zone in alarm with a flashing zone number display. To prevent alarm on startup, Lo alarm is not activated until all enabled zones cross Lo alarm setpoint. The CN600 Series implements a security password to protect certain functions.

1.2 Features

- Six Zones or 12 Zones
- Adjustable Display Time
- Field Proven Zone Switching
- Temperature and Setpoint Monitoring
- Four Digit Display of Temperature
- 2 Digit Display of Zones
- 5 Amp Latching or Non-Latching Relay
- Standard Thermocouples [T,E,J,K,S,R,B,C]
- Extended Ranges
- Six RTD Inputs (2 or 3 wire)
- Six Optional Independent Outputs
- Programmable Selection of HI, LO or HI/LO Alarms
- Password Protection
- Optional Inputs Other Than Thermometer
- 1/4 DIN Aluminum Box
- Splash Proof Face
- Plug-In I/O Terminals
- RS-232 Communication

NOTE: Consult RS-232 Software for use of RS-232 Communications.

1.3 Models

The following Models are available:

- Standard Thermocouple
- Extended Range
- RTD Input
- 12 Zone Thermocouple

Model Number	Description
CN606TC1	6 Zone T/C
CN606TC2	6 Zone T/C w/Extended Range
CN606RTD	6 Zone RTD (2 Wire)
CN606RTD-C	6 Zone RTD (2 Wire) Copper
CN612RTD	12 Zone RTD (2 Wire)
CN612RTD-C	12 Zone RTD (2 Wire) Copper
CN606RTD-3	6 Zone RTD (3 Wire)
CN606RTD-3C	6 Zone RTD (3 Wire) Copper
CN612TC1	12 Zone T/C
CN612TC2	12 Zone T/C w/Extended Range

(Open Collector Option)

CN606TC1-OC	6 Zone T/C
CN606TC2-OC	6 Zone T/C w/Extended Range
CN606RTD-OC	6 Zone RTD (2 Wire)
CN606RTD-OC-C	6 Zone RTD (2 Wire) Copper

SECTION 2 RS-232 COMMUNICATIONS

2.1 Description

NOTE: Minimum requirements to run RS-232 software is a PC computer with Windows 95.

Up to ten scanners can be connected in parallel to a single RS-232 communications port on a PC. Each scanner is assigned a serial number from 0 to 9. The computer uses these numbers to determine which scanner unit to address at a given time.

A simple set of menus is provided in the software which allows the operator to change the settings of each connected scanner unit and display individual operating parameters.

For users with advanced software capabilities, see Section 2.4 for an operating protocol.

2.2 RS-232 Cable Connections

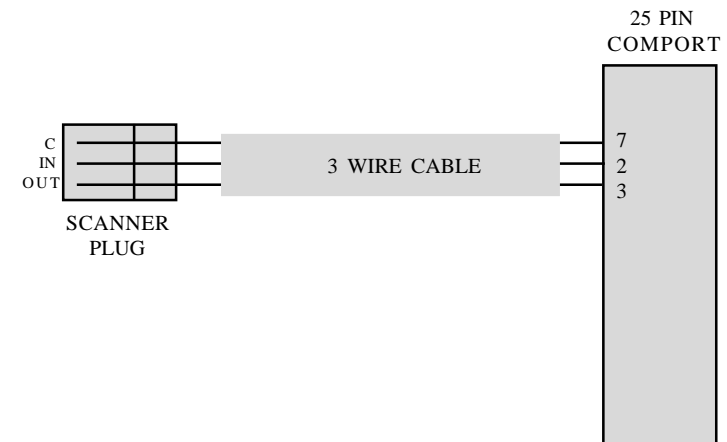
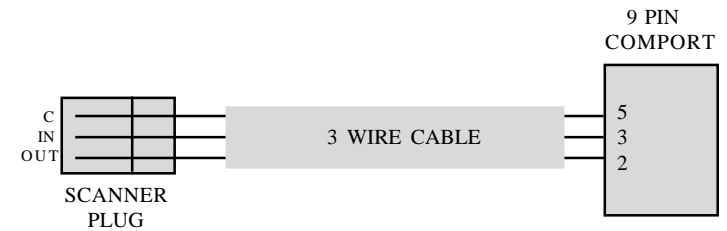

2.3 RS-232 PC Screens

The following screen menus are provided:

1. SELECT PORT- Scans all available PC ports and indicates which port is connected to scanners.

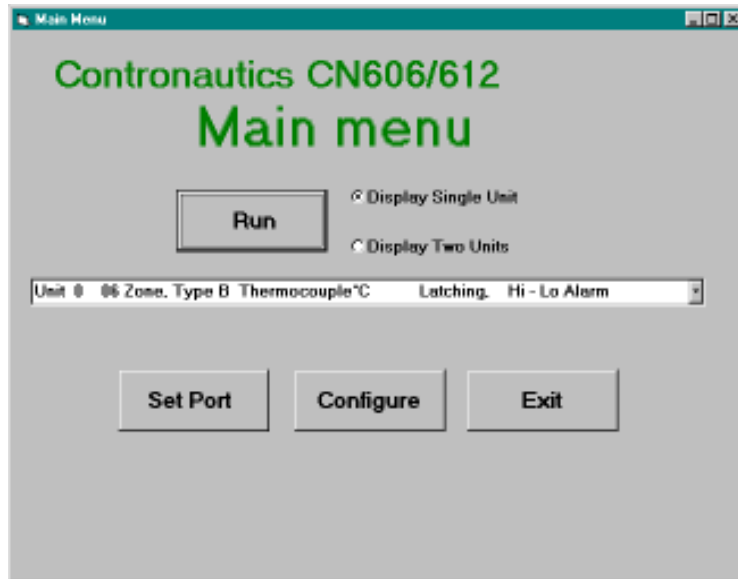

2. MAIN MENU- Allows the following operations:

- RUN one unit display or two units simultaneously.

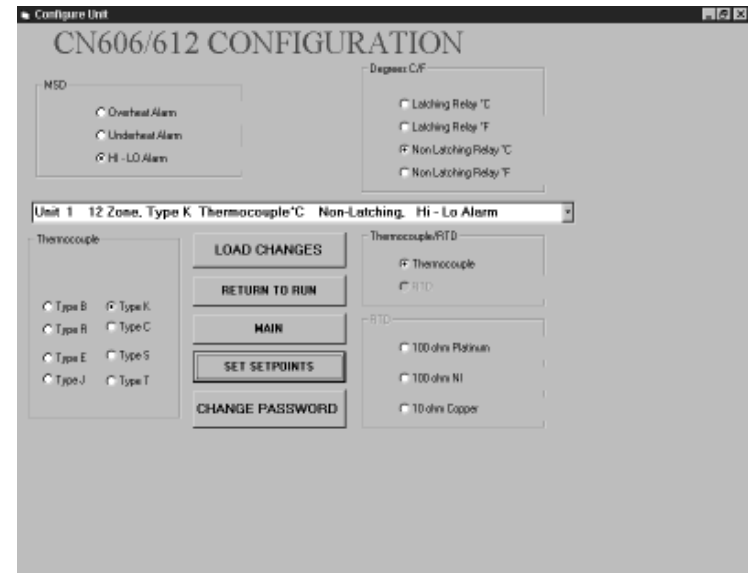
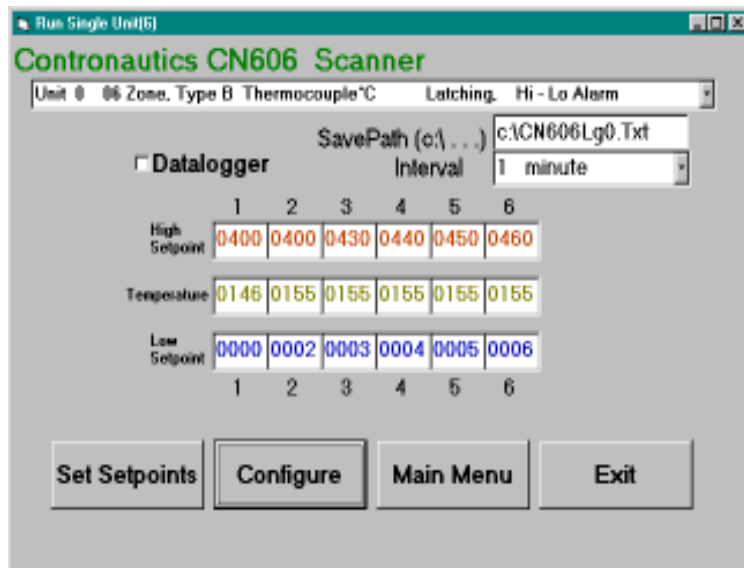

- CONFIGURE UNIT allows individual unit type selection, including: T/C Type, Temperature Scale, Latching or Nonlatching Alarm, and Hi, Lo or Hi/Lo Alarm.

- SET SETPOINTS allows changes to individual unit Hi and Low setpoints, scan time settings and allows zones to be enabled/disabled.

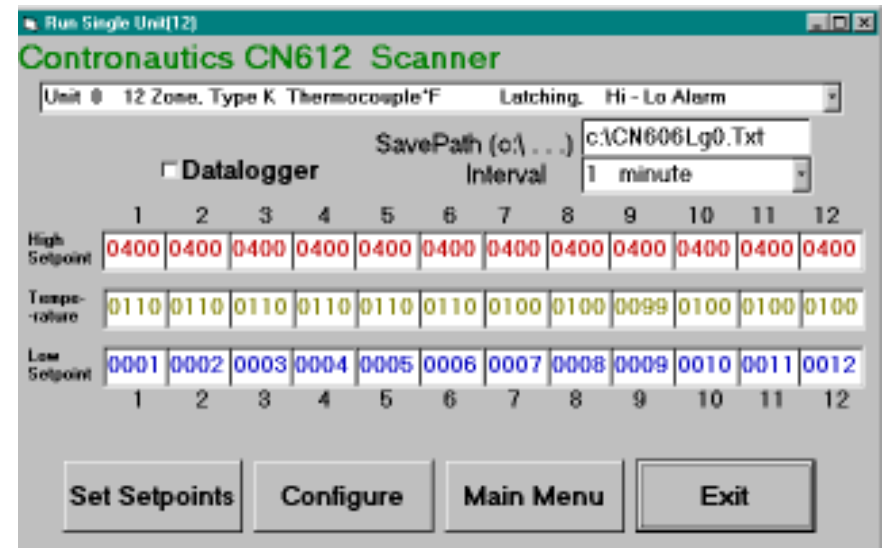

2.4 Operating Protocol for RS-232 Communications

The CN606 Scanner is designed with standard RS-232 three wire serial communication capabilities. Up to ten scanners can be parallel connected to a single PC. The transmission line is held in tristate to avoid cross-talk between scanners except when the computer addresses a specific scanner for communication.

Configuration

BAUD rate = 4800

Data bits = 8

Parity = N

Stop = 1 (or 2 on some computers)

Communication software for the PC is written in Visual Basic. This software package has been created to operate on PC Windows 95 platform meeting the minimum requirements.

Customers can communicate with CN606 scanners through a PC by using the following protocol:

- Scanners will not initiate communication. The RS-232

Command Module (computer or similar device) must initiate.

- All communication is in ASCII format except Check Sum.

Check Sum is generated by hexadecimal addition with carry of data string (one byte).

• To start communication, the Command Module must send alert code ASCII [L] hex 4C. This commands the scanners to cease RS232 communication and listen for an ID Code. The Command Module then sends the Identification Number for the scanner that it needs to address, ASCII [0 to 9] hex 30 to 39. The identified scanner will then expect a command code. All the other scanners on-line will wait for the next alert code.

- Command codes are divided into two groups:

Group 1. Commands requesting data from the scanner:

ASCII [A] hex 41 = Zones/ Alarms/ Scan time

ASCII [M] hex 4D = Model/ Password/ ID#/ # of zones

ASCII [S] hex 53 = Setpoints

ASCII [T] hex 54 = Temperature

ASCII Zones/ Alarms/ Scan time	15 bytes
1 byte [binary] zones 1 to 6	[0011 1111]=(3Fh)
1 byte [binary] zones 7 to 12	[0011 1111]=(3Fh)
1 byte [binary] zones 1 to 6 Hi alarm	[0011 1111]=(3Fh)
1 byte [binary] zones 7 to 12 Hi alarm	[0011 1111]=(3Fh)
1 byte [binary] zones 1 to 6 Lo alarm	[0011 1111]=(3Fh)
1 byte [binary] zones 7 to 12 Lo alarm	[0011 1111]=(3Fh)
2 digit scan time	
+ check sum	

ASCII Model/ Password/ ID#/ # of zones	13 bytes
4 digit model code	4 bytes
4 digit password	4 bytes
2 digit ID#	2 bytes
2 digit number of zones	2 bytes
+ check sum	1 byte

ASCII Coded Setpoints	97 bytes
12 zones, 4 digits each zone [Lo setpoint]	48 bytes
12 zones, 4 digits each zone [Hi setpoint]	48 bytes
+ check sum	1 byte

ASCII Coded Temperature	49 bytes
12 zones, 4 digits each zone	48 bytes
+ check sum	1 byte

Group 2. Commands preparing scanner to receive data:

ASCII [m] hex 6D = Model/ Password/ ID#

ASCII [e] hex 65 = Zone enable/ Scan time

ASCII [s] hex 73 = Setpoints

ASCII Model/ Password/ ID#	10 bytes
4 digit model code	4 bytes
4 digit password	4 bytes
1 byte ID	1 byte
+ check sum	1 byte

ASCII Zone enable/ Scan time	7 bytes
1 byte [binary] zones 1 to 6 [0011 1111]	2 bytes
1 byte [binary] zones 7 to 12 [0011 1111]	2 bytes
2 digit scan time	2 bytes
+ check sum	1 byte

ASCII Coded setpoints	97 bytes
12 zones, 4 digits each zone [Lo setpoint]	48 bytes
12 zones, 4 digits each zone [Hi setpoint]	48 bytes
+ check sum	1 byte

- The four digit code for model selection is as follows:

Digit 1. (msd)

- 0 = Overheat Alarm
- 1 = Underheat Alarm
- 2 = Hi/ Lo Alarm

Digit 2.

- 0 = Latching Relay °C
- 1 = Latching Relay °F
- 2 = Nonlatching Relay °C
- 3 = Nonlatching Relay °F

Digit 3. (preset at the factory)

- 0 = Thermocouple
- 1 = RTD

Digit 4. (Thermocouple units only)

- 0 = Type B
- 1 = Type C
- 2 = Type E
- 3 = Type J
- 4 = Type K
- 5 = Type R
- 6 = Type S
- 7 = Type T

Digit 4. (RTD units only)

- 0 = 100 ohm Platinum
- 1 = 100 ohm Nickel
- 2 = 10 ohm Copper

SECTION 3 INSTALLATION

3.1 Unpacking

Upon receipt of shipment, inspect the container and equipment for any signs of damage. Take particular note of any evidence of rough handling in transit. Immediately report any damage to the shipping agent.

Remove the packing list and verify that all equipment has been received. Each package should contain:

- Scanner (CN606 or CN612)
- Operator's Manual
- RS-232 Software
- Two mounting slides with screws
- Power plug (9 pin)
- RS-232 plug (3 pin)
- Two T/C plugs (6 pin)
- (CN612 only) Two Additional T/C plugs (6 pin)

If there are any questions about the shipment, please call the Customer Service Department.

NOTE: The carrier will not honor any claims unless all shipping material is saved for their examination. After examining and removing contents, save packing material and carton in the event reshipment is necessary.

3.2 Mounting

Select a location for the monitor that is free from excessive shock, vibration, dirt, moisture and oil. Mount the monitor into a 3 5/8" (92mm) square cutout. The monitor as shipped is 1/4 DIN (92mm square), so it does not have to be removed from its housing to be mounted.

Remove the two screws that secure the mounting slides. Remove the slides and insert the case into the cutout from the front side of the panel. Reinstall the two slides and two screws. The length of the slides must be reduced if the monitor is to be mounted in an extra thick panel.

3.3 Outline Dimensions

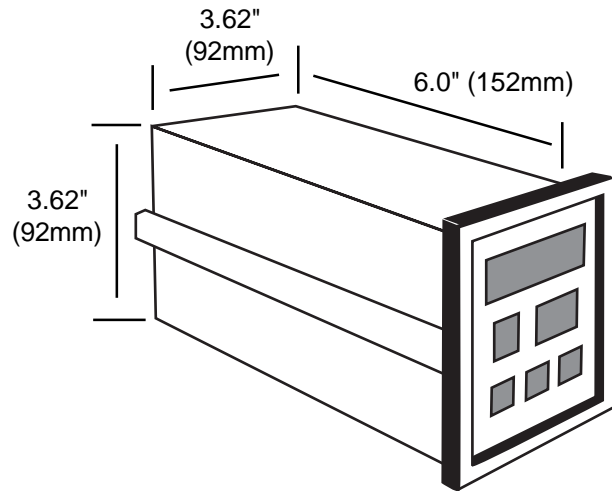

3.4 Wiring the Power Circuit

The line voltage for the scanner is selected by an external jumper assembly to operate either on 120VAC or 240VAC±10%, 50/60Hz (factory wired for 120VAC). It is very important that the proper line voltage is connected to the instrument. If 120VAC is connected to a 240VAC model, it will not work properly. A 120VAC instrument connected to 240VAC will overheat and burn the input transformer.

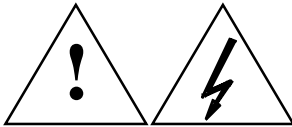

WARNING! !

The scanner is powered with either 120 or 240 VAC. To avoid electric shock or fatality hazards the power to the scanner lines must be switched off at the main switch, or circuit breaker before the scanner A/C wiring, including the line selector jumpers can be handled.

3.5 Changing Line Voltage Setting

Program the input line voltage by placing jumpers on the line plug as shown:

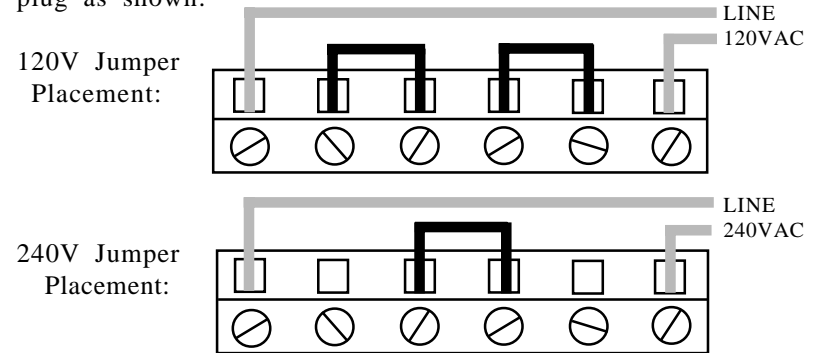

**WARNING! !
Line Voltage
see P 10**

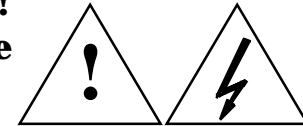

3.6 Sensor Placement

Proper sensor placement is essential. It can eliminate many problems in the total system. The probe should be placed so that it can detect any temperature change with little thermal lag. In a process that requires fairly constant heat output, the probe should be placed close to the heater. In processes where the heat demand is variable, the probe should be close to the work area. Experimenting with probe location can often provide optimum results. Some RTDs are shock sensitive and require care in handling and installation. To avoid current feedback from zone to zone and from zone to RS-232 communications, ungrounded thermocouples are recommended. Thermocouple wires should not be placed in the same conduit as the power lines.

SECTION 4 PARTS OF THE INSTRUMENT

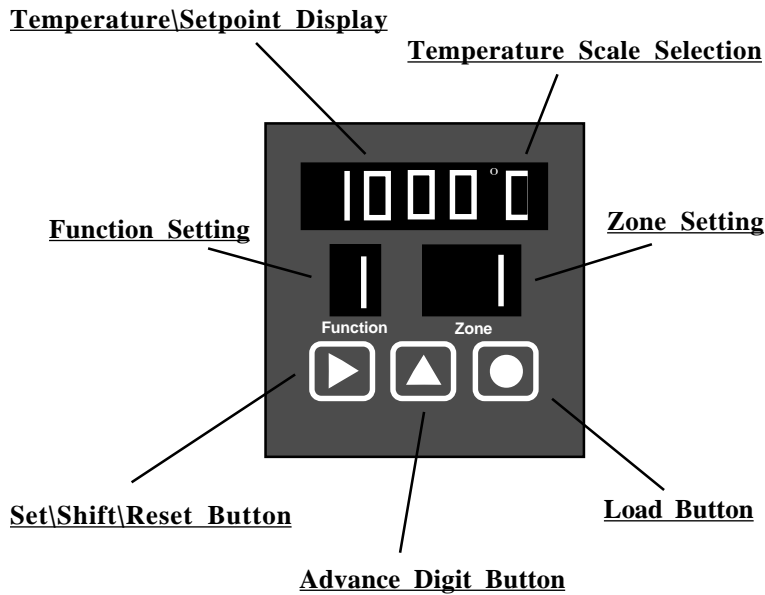

Temperature\Setpoint Display- Main display with multiple functions.

Temperature Scale Selection- Choice of °C or °F.

Function Setting- Indicates the operating status of the instrument.

Zone Setting- Indicates an active zone or a zone that is being set.

Set\Shift\Reset Button- Used to recall the setpoint, to select digits during setup or to reset the alarm.

Advance Digit Button- Used to increment selected digit.

Load Button- Used to accept a setting.

4.2 Button Functions

There are three flatpad buttons provided and two combinations for separate functions.

Set/Shift/Reset Button



1. Selects Digit
2. Enables/Disables Zones
3. Resets Alarm during "RUN" MODE
4. Switches Main Display Functions

Advance Digit Button



1. Advances Selected Digits
2. Advances Zones

Load Button



Advance Digit Button & Load Button (together)



1. Requests the Password
2. Engages Function Select

Set/Shift/Reset Button & Load Button (together)



1. Displays the Setpoint during "RUN" MODE
2. Exits Setpoint Display during "FUNCTION SELECT" MODE

4.3 Back of the Scanner

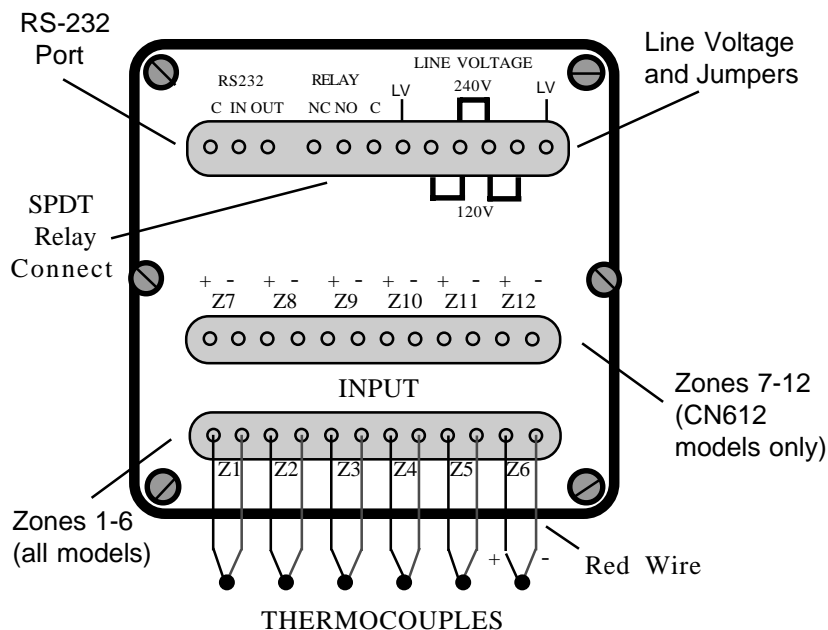

WARNING! !
Line Voltage
see P 10

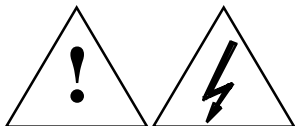

RS-232 Port- Cable connection (see Section 1.3)

C - Common	Pin 5	} 9 Pin Comport
IN - Input	Pin 3	
OUT - Output	Pin 2	

Relay

NC- Non-energized Closed
 NO- Non-energized Open
 C- Common

Line

LV- 120VAC or 240VAC cable

Jumpers- Determines voltage input (see Section 3.4)

4.4 Temperature/Setpoint Display (Main Display)



During **"RUN" MODE**, the Main Display is used to monitor zone temperatures, check setpoints, and indicate ALARM conditions.

During operator programming in **"FUNCTION SELECT" MODE**, the Main Display is used to:

1. Set the Zone Setpoints
2. Enter Passwords
3. Select Functions
4. Set the Zone Display Time
5. Select the Instrument Model

During **CALIBRATION** (Function 9), the Main Display is used to:

1. Set calibration millivolts



SECTION 5 SETUP AND OPERATION

There are two methods of setting up the CN600 Series scanner. The CN600 Series can be easily configured using the RS-232 Communications software or the scanner can be set up through it's front panel by using the following instructions.





5.1 "RUN" MODE

Once the instrument is mounted and powered, it will go into **"RUN" MODE**. This is the basic operating mode for the CN606 in which each zone is sequentially scanned at approximately 4 complete scans per second (all zones) and each active zone is displayed for the scan time set by the operator (1 to 39 seconds). The last settings loaded will control the instrument.

During **"RUN" MODE**, the operator is able to perform the following separate functions:

1. Check individual Setpoints by pressing  & 

NOTE: In HI/LO Alarm Mode, the operator may toggle between HI and LO Setpoints by pressing 

2. Lock individual Zones for monitoring by pressing 
Unlock with 
3. Activate **"FUNCTION SELECT"** by pressing  & 

NOTE: If the Password Function is enabled, the correct Password must be entered to access **"FUNCTION SELECT"**

5.2 Functions

Functions are selected on the Main Display during **"FUNCTION SELECT" MODE** and transferred to the Function Display by the  button.

Ten Functions are available:

Manual Section	FUNCTION DISPLAYED	DESCRIPTION
5.1	0	"RUN" MODE (Monitor Zone Temperatures, Setpoints, Alarms)
5.4	1	"FUNCTIONSELECT" (Password Protection Option)
5.3	2	Select Active Zones (Activate or Disable Zones)
5.3	3	Set LO Setpoint
5.3	4	Set HI Setpoint
5.3	5	Serial Number (to set a one digit Instrument RS-232 address)
5.3	6	Set Scan Time (1 to 39 seconds)
5.3	7	Select Model (four digit model #: Alarm, Relay & F/C, Input, Type)
5.3	8	Password Enable/Disable
5.3	9	Calibration (with a Fixed Password)

5.3 Functions Description



RUN

This is the basic operating mode entered on power-up. See SECTION 5.1



FUNCTIONSELECT

This is the function from which most other Functions are available. See SECTION 5.4



SELECTACTIVEZONES



During **"FUNCTION SELECT"**, use  to select "2" on the Main display.

Press  to load.

The Main Display will become blank.
A "2" will be shown in the Function Display.
Zone "1" will be indicated in the Zone Display.

On the Zone display: Flashing "1" = Current Zone Disabled
Steady "1" = Current Zone Active

Push  to change the status of the zone.

When the correct zone status is set, push  to advance to the next zone.
Set the status of each zone and press  to load all zones

and return to **"FUNCTION SELECT" MODE**.





SETLOSETPOINT

During **"FUNCTION SELECT"**, select "3" on the Main display.
Load with 

A "3" will appear in the Function Display.
The current zone will appear in the Zone Display.
The Main Display will show the current setpoint with it's



first digit flashing.
If changes are required:

Increment digit with 

Select digit with 

Load with  and the next zone will appear.

If no changes are required, push  to check the next zone.

When the setpoints for each zone have been checked or corrected, press  &  together to return to **“FUNCTION SELECT” MODE.**



Function

SETHISETPOINT

Repeat procedure for "LO SETPOINT" but begin with selecting Function "4" and then set each zone's HI setpoint.



Function

SERIALNUMBER

One Digit Instrument Serial Number. Used for RS-232 addressing. Follow the same procedure as for Function 6 but select Function 5.





Function

SETSCAN TIME

During "FUNCTION SELECT", select "6" on the Main display.

Load with 

A "6" will appear in the Function Display.
Two "Scan Time" digits will appear in the Temp. Display.
Set the required scan time (within 1 and 40 seconds) using

 to increment and  to select digit.

Press  to load and return to **“FUNCTION**

SELECT”MODE.



Function



SELECTMODEL

During "FUNCTION SELECT", select "7" on the Main Display.

Load with 

A "7" will appear in the Function Display.
A four-digit Model number will appear in the Main Display.
Each digit represents an option available within the instrument.

Choose a number for each digit that suits your needs.

Increment with  and select next digit with  to choose

the proper model from the list below:

First Digit	0-	Overheat Alarm
(MSD)	1-	Underheat Alarm
	2-	HI-LOAlarm

Second Digit	0-	Latching relay °C
	1-	Latching relay °F
	2-	Non Latching Relay °C
	3-	Non Latching Relay °F

Third Digit (Factory Preset)

	0-	Thermocouple
	1-	RTD

Fourth Digit (Thermocouple) (RTD)

	0-	Type B	0	100 ohm Platinum
	1-	Type C	1	100 ohm NI
	2-	Type E	2	10 ohm Copper
	3-	Type J		
	4-	Type K		
	5-	Type R		
	6-	Type S		
	7-	Type T		

Press  to load.

The instrument will return to **"FUNCTION SELECT" MODE.**



PASSWORDENABLE/DISABLE

Select "8" on the Main Display.

Press to load.

An "8" will appear in the Function Display.

The first digit on the Main Display will flash "0" or "1", depending on the previous setting.

To enable Password, enter "1" on the Main Display.

To disable Password, enter "0" on the Main Display.

Load and Exit with .



CALIBRATION

NOTE: To avoid any interference during calibration, disconnect the RS-232 wires from the scanner.

THERMOCOUPLE UNIT WIRING: Parallel-connect all thermocouple terminals of the Input Connector as shown:

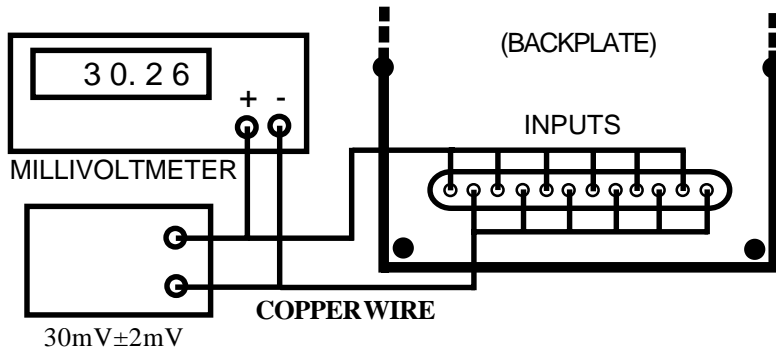

Using copper wire, connect the positive and negative terminals of the Input connector to a precision millivoltmeter and a low output impedance source (10 ohm or less) set to 30mV ±2mV input.

Set main display with buttons to display four digit reading of the precision millivoltmeter. Then enter with button. When calibration is finished the unit will return to "RUN" mode.

RTD UNIT WIRING: Connect the upper Input Connector as shown on next page. In the lower Input Connector, connect a 330Ω ±5% resistor across each zone except Zone 3.

Using copper wire, connect Zone 3 to a precision 300Ω±0.01% or 20Ω±0.01% resistor as shown:

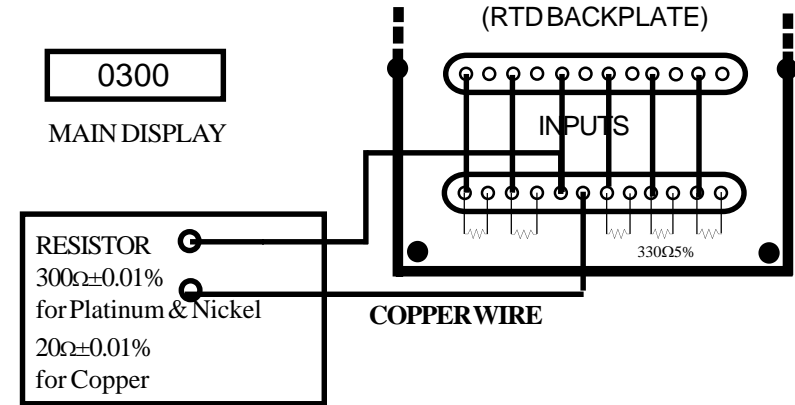

Allow the instrument to run for 15 minutes before calibrating. During "FUNCTIONSELECT", select "9" on the Main Display. Press to load.

A "9" will appear in the Function Display and the Main Display will flash "0". A Fixed Password (0101) is now required to enter this Function to protect against accidental miscalibration. Follow the password entry procedure in Section 5.6.

Platinum and Nickel Model

Main display will flash "0300"

Copper Model

Main display will flash "0020"

Press to load and activate SELF CHECK.

For about 20 seconds, the display will flash the digits as shown:

During this time, the scanner checks and calibrates itself.





NOTE: Do not change the impedance source or resistor input during this SELF CHECK PERIOD.

When SELF CHECK is finished, the display returns to "RUN" MODE and CALIBRATION IS COMPLETED

5.4 "FUNCTION SELECT" MODE

"FUNCTION SELECT" is the mode through which most Functions are accessible.

To access "FUNCTION SELECT" MODE, press  &  together while in "RUN" MODE.

A "1" should appear in the Function Display. If it flashes, then the instrument is in "FUNCTION SELECT". If the "1" is steady, a Password is required.

When in "FUNCTION SELECT" MODE, the fourth digit in the Main Display will flash "0".

Use  to increment this

digit to the desired Function number (2-9) chosen from the Functions List.

Press  to load.

The Function number selected will transfer to the Function Display and information relevant to that Function will appear in the Main and Zone Displays.

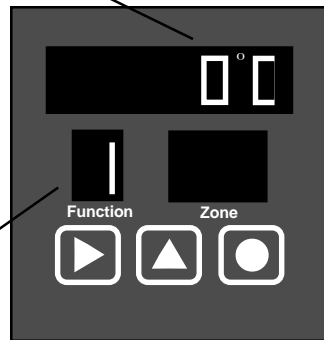

5.5 Security



The instrument is factory preset with a Four Digit Password (1011) to restrict access to settings.

The Password can be enabled or disabled within Function 8 of the instrument. (If enabled, follow procedure 5.3)

The Password can only be changed by computer using RS-232. There is also a fixed password to enter Function 9 Calibration.

5.6 Entering the Password (Factory Preset) to access FUNCTION SELECT MODE

NOTE: The Password can only be changed by a computer using RS-232 Communications.

During "RUN" MODE, press  and  together to access "FUNCTION SELECT" MODE. If the Password security is enabled, a steady "1" will appear in the Function Display and the first digit in the Main Display will flash "0". If the Password security is disabled, a "1" will flash in the Function Display and the last digit in the Main Display will flash "0".

TO ENTER PASSWORD 1011

1. Press  to increment the first digit to "1".

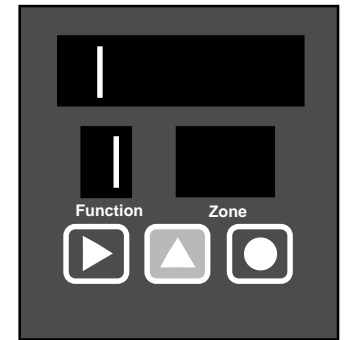

1.

2. Press  to shift to the second digit. In this case, the second digit of the password is a "0"; there's no need to increment it.

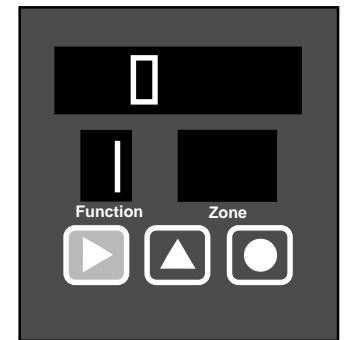

2.

3. Press  again to shift to the third digit.

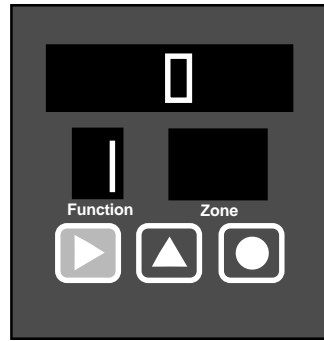

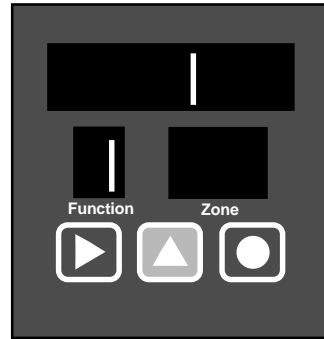

3.

4. Press  to increment the third digit to "1".



4.

5. (Not illustrated) Shift to the fourth digit with  and increment the display to "1" with .

6. Push  to load the password.

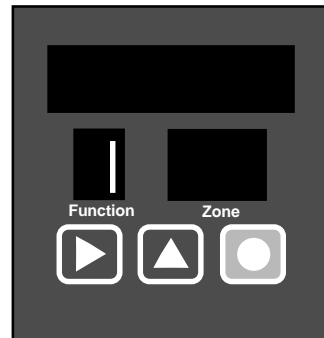

6.

NOTE: If wrong password is entered, the instrument will go back to **“RUN” MODE**.

If password is correct, “1” in the function display will start flashing and the instrument will go to **“FUNCTION SELECT”**. In **“FUNCTION SELECT”** MODE the operator may choose a Function from the FUNCTIONS list.

5.7 Wiring RTD Models

NOTE: See Section 4.3 for thermocouple wiring.

Six Zone RTD-3 Wire

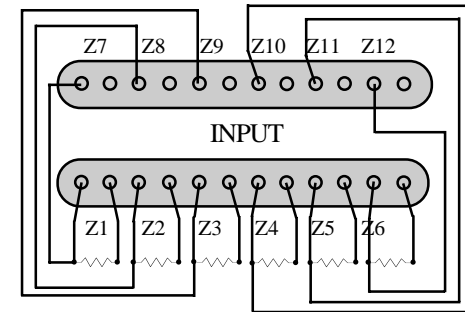

3 Wire Model

using 2 Wire Probe
(Short Upper Terminals as shown)

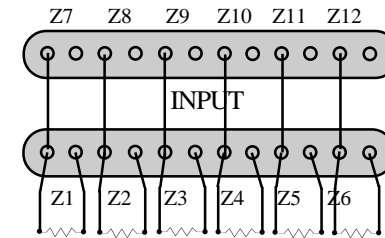

Twelve Zone RTD-2 Wire only

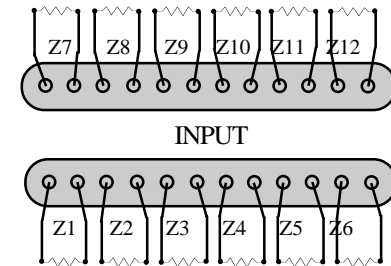

5.8 Wiring OC Models

Output

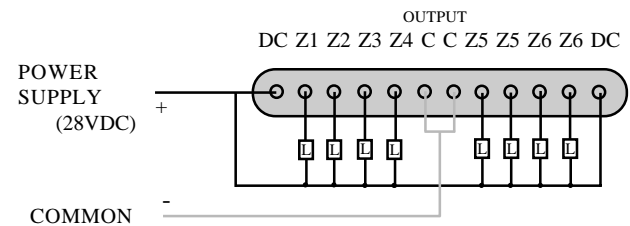

Open Collector Transistor Diagram for Output

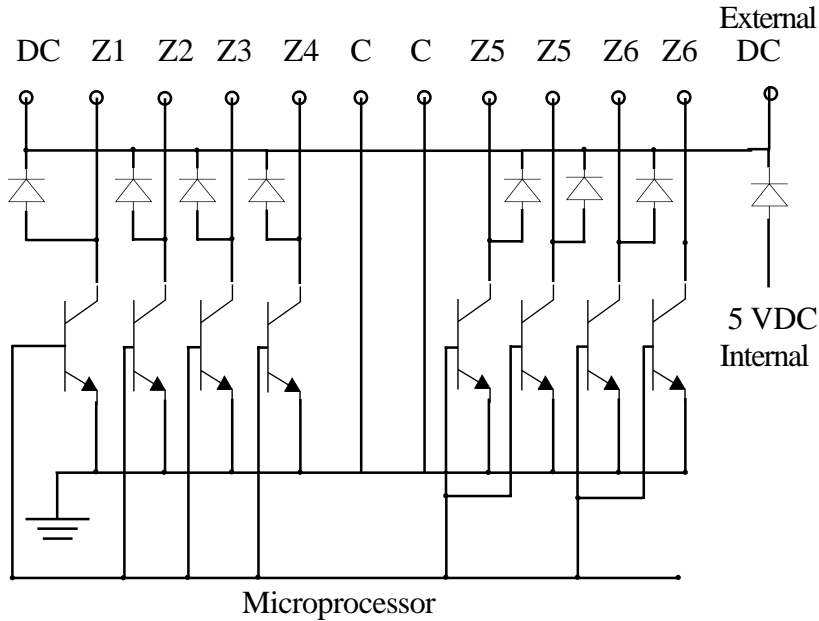

5.9 Thermocouple Ranges

Standard Ranges		
TC	°C Range	°F Range
J	0-750	32-1400
K	0-1000	32-1900
E	0-500	32-1000
T	0-400	32-750
S	0-1750	32-3200
R	0-1750	32-3200
B	0-1800	32-3300
N	0-1100	32-2100
C	0-2300	32-4200
Extended Ranges		
K	0-1300	32-2500
E	0-1000	32-1800
RTD Ranges		
100Ω Platinum	0-600	32-1200
120Ω Nickel	0-300	32-600
10Ω Copper	0-250	32-500

**SECTION 6
SPECIFICATIONS**

No. of Zones	Six standard/ Twelve Expanded
Zone Display Time Adjust.	1-40 seconds
Scan Time	Approx. 1/4 sec
Input Range	0-40mV Standard/ 0-75mV Expanded
Accuracy	±0.1% Range ±1 °C
Resolution	±5uV
Thermocouple Type	J,K,E,T,S,R,B,N,C
Cold Junction Compensation	Automatic
Linearity	±1 °C
Scale Selectable	°C or °F
Open T/C Warning	Flashing Display
RTD (2 or 3 wire)	100Ω Pt 100Ω Ni 10Ω Cu
Line Power	120/240VAC; 50/60Hz
Power Consumption	10VA Max.
Alarm Relay	5 Amp; 120VAC Relay deenergizes on alarm
Optional 6 Outputs (One for each Zone; Open Collector Transistors deenergize on alarm)	.5Amp@40VDC External DC power required
Communication	RS232 (3wire)
Alarms Selectable	HI } Latching or LO } Non-latching HI/LO }
Alarm Range	Full Range
Terminals	Headers for Plug-in Wiring
Enclosure	1/4 Din Aluminum, 6" long
Reset	Manual
Max. Voltage between Inputs	6VDC or RMS
Reaction to Power Loss	Unit returns to "RUN" MODE
Main Display	Four Digit; 0.6" high